

DESCRIPTION:
SNAPRACK, RL UNIVERSAL, LINK

PART NUMBER(S):
242-02156

DRAWN BY:
 mwatkins

REVISION:
A

SnapNrack™
 Solar Mounting Solutions

595 MARKET STREET, 29TH FLOOR • SAN FRANCISCO, CA 94105 USA
 PHONE (415) 580-6900 • FAX (415) 580-6902

THE INFORMATION IN THIS DRAWING IS CONFIDENTIAL AND PROPRIETARY. ANY REPRODUCTION, DISCLOSURE, OR USE THEREOF IS PROHIBITED WITHOUT THE WRITTEN CONSENT OF SUNRUN SOUTH LLC.

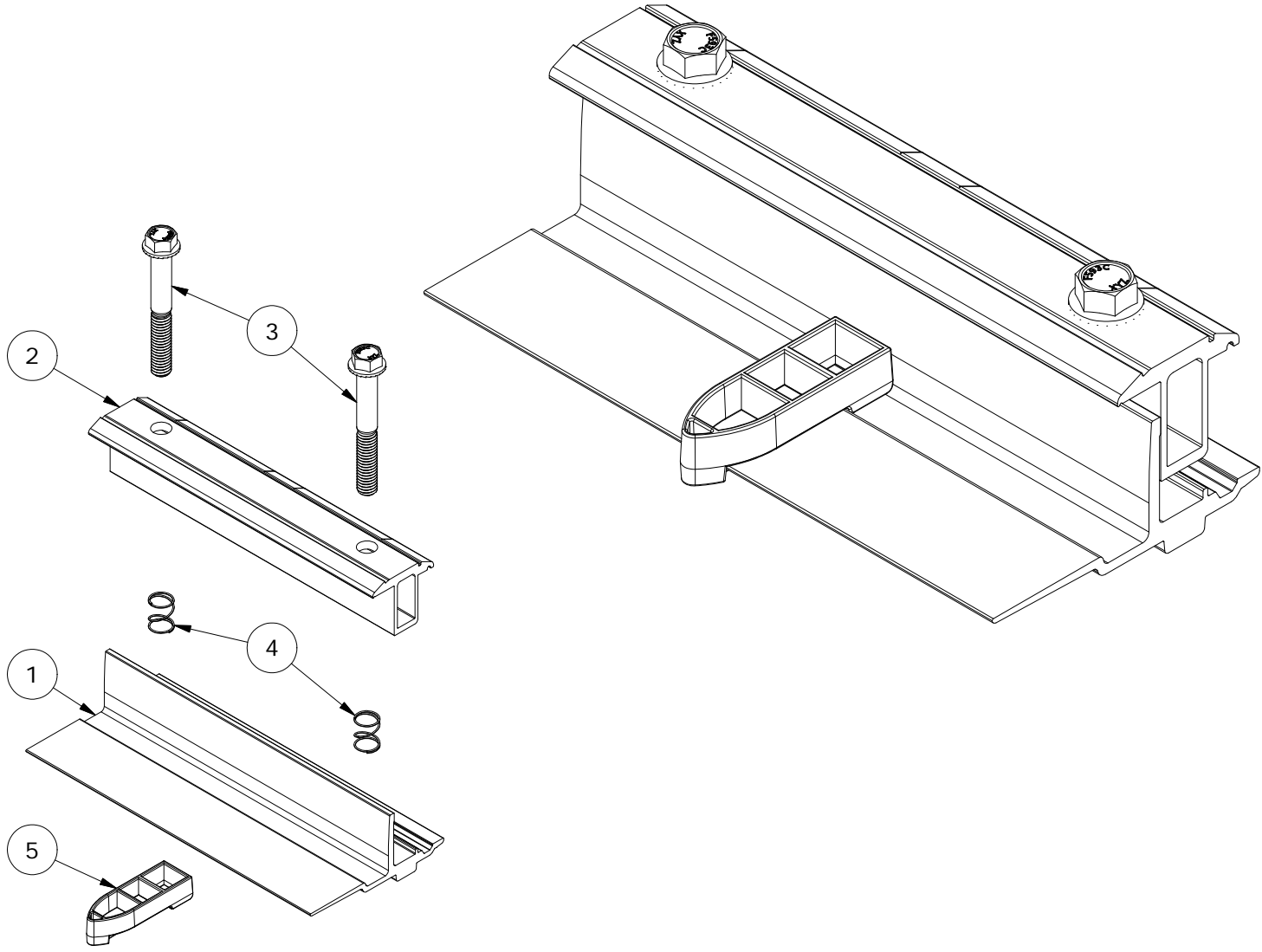

PARTS LIST

ITEM	QTY	DESCRIPTION
1	1	SNAPNRACK, RL UNIVERSAL, LINK BOTTOM, MILL
2	1	SNAPNRACK, RL UNIVERSAL, LINK TOP, BONDING, BLACK
3	2	BOLT, FLANGE, SERRATED, 3/8IN-16 X 2-3/4IN, 1/2IN TRIM HEAD, 1.2IN THREAD, BLACK, SS
4	2	SNAPNRACK, RL UNIVERSAL, MOUNT SPRING, SS
5	1	SNAPNRACK, RL UNIVERSAL, LINK COLUMN SPACER

MATERIALS:	6000 SERIES ALUMINUM, STAINLESS STEEL, POLYCARBONATE	OPTIONS:
DESIGN LOAD (LBS):	N/A	
ULTIMATE LOAD (LBS):	N/A	
TORQUE SPECIFICATION:	12 LB-FT	
CERTIFICATION:	UL 2703, FILE E359313	
WEIGHT (LBS):	1.03	

DESCRIPTION:

SNAPNRACK, RL UNIVERSAL, LINK

DRAWN BY:

mwatkins

REVISION:

A

SnapNrack™
Solar Mounting Solutions

PART NUMBER(S):

242-02156

595 MARKET STREET, 29TH FLOOR • SAN FRANCISCO, CA 94105 USA
PHONE (415) 580-6900 • FAX (415) 580-6902

THE INFORMATION IN THIS DRAWING IS CONFIDENTIAL AND PROPRIETARY. ANY REPRODUCTION, DISCLOSURE, OR USE THEREOF IS PROHIBITED WITHOUT THE WRITTEN CONSENT OF SUNRUN SOUTH LLC.

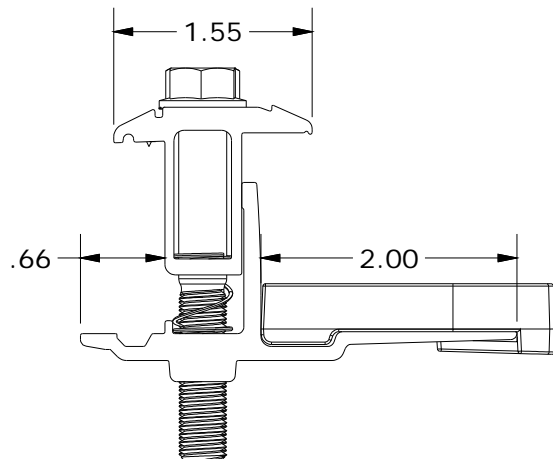
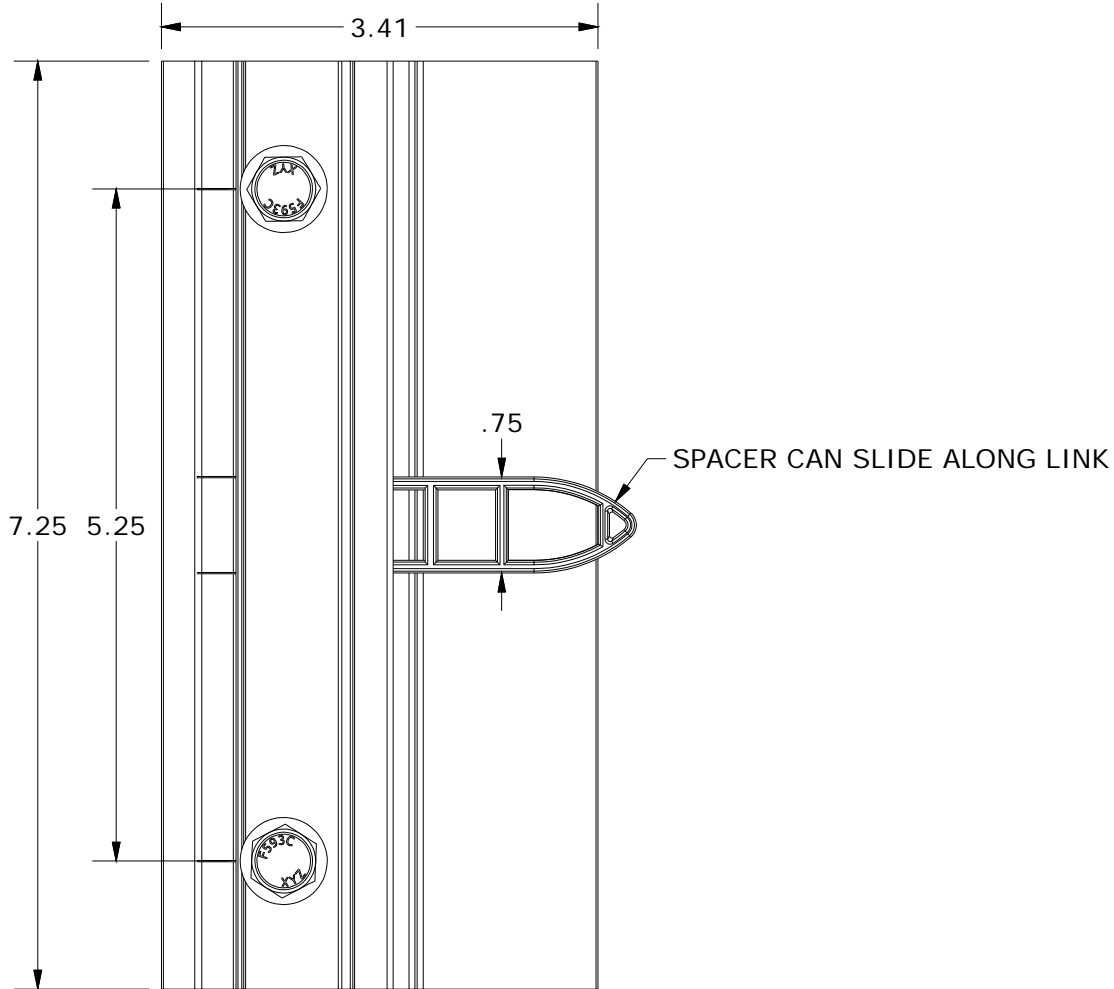

ALL DIMENSIONS IN INCHES